

THIS DRAWING IS UNPUBLISHED. RELEASED FOR PUBLICATION
 © COPYRIGHT BY TYCO ELECTRONICS CORPORATION. ALL RIGHTS RESERVED.

LOC	DIST	REVISIONS				
P	LTR	DESCRIPTION	DATE	DWN	APVD	
DW	-	A1	REVISED (ECR-11-008817)	29MAY11	SC	WK

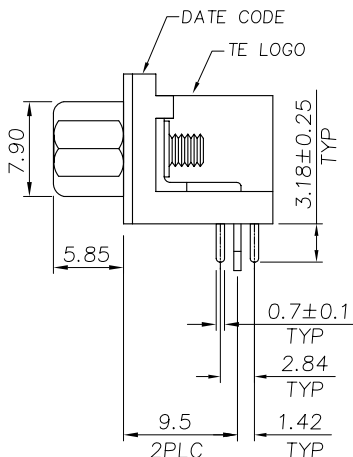
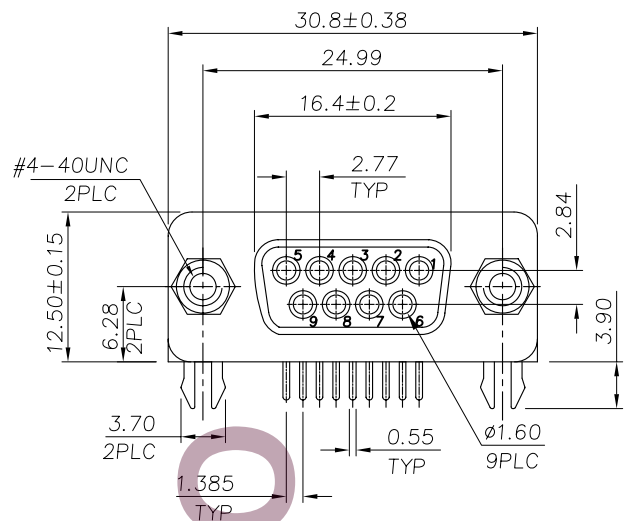

NOTES:

1. MATERIAL:

HOUSING: THERMOPLASTIC(PBT), UL94V-0, BLACK COLOR
 CONTACT: BRASS
 SHELL: STEEL
 BOARDLOCK: BRASS

2. FINISH:

CONTACT: GOLD FLASH PLATED ON CONTACT AREA
 2.54um[100u"] MIN. BRIGHT TIN PLATED ON SOLDERTAILS
 1.27um[50u"] MIN. NICKEL UNDERPLATED OVERALL
 SHELL: 2.032um[80u"] MIN. NICKEL PLATED
 BOARDLOCK: 2.54um[100u"] MIN. BRIGHT TIN PLATED ON SOLDERTAILS
 1.27um[50u"] MIN. NICKEL UNDERPLATED OVERALL

3. RECOMMENDED P.B.C. THICKNESS: 1.0~1.8mm

▲ PN1734717-3 HAS SEPARATE PACKING SCREW.

5. WAVE SOLDER CAPABLE TO 240°C .

SCREW OPTION

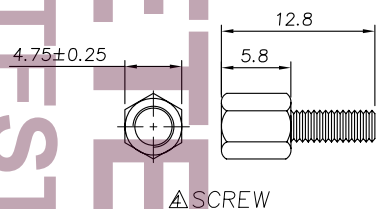
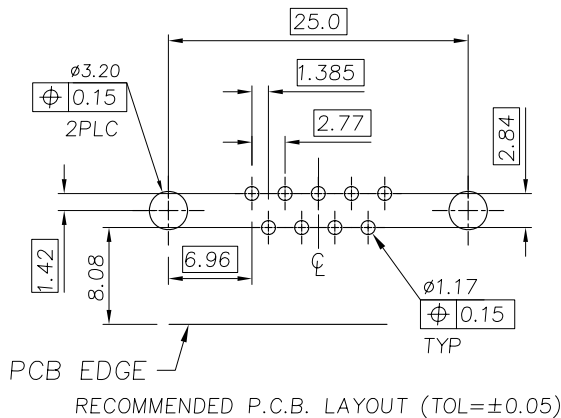
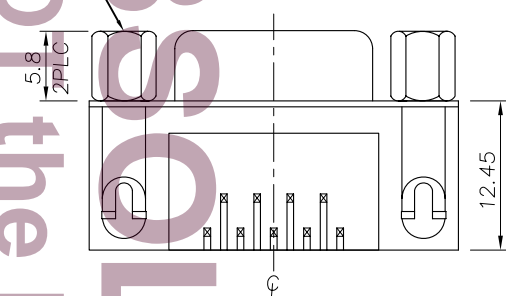

	W/O	1734717-2
OBSOLETE	W/ ▲ SEPERATED	1734717-3
	W/ LOCKED	1734717-1
	SCREW	PART NUMBER

THIS DRAWING IS A CONTROLLED DOCUMENT.		DWN S. CHIEN 28OCT2008	TE Connectivity	
DIMENSIONS: MM		CHK S. CHIEN 28OCT2008		
TOLERANCES UNLESS OTHERWISE SPECIFIED:		APVD W. KODAMA 28OCT2008	NAME	
0 PLC ± -	1 PLC ± 0.30	PRODUCT SPEC 108-57540	D-SUB 9POS. RCPT, R/A DIP TYPE	
2 PLC ± 0.20	3 PLC ± -	QUALIFICATION TEST REPORT 501-57622	SIZE A3	CAGE CODE 00779
4 PLC ± -	ANGLES ± 3'	MATERIAL FINISH	DRAWING NO C=1734717	
SEE NOTE	SEE NOTE	WEIGHT --	SCALE -- SHEET 1 of 3 REV A1	
CUSTOMER DRAWING				

REVISION NO the LATEST OBSOLETE

4

3

2

1

THIS DRAWING IS UNPUBLISHED. RELEASED FOR PUBLICATION
© COPYRIGHT BY TYCO ELECTRONICS CORPORATION. ALL RIGHTS RESERVED.

LOC DW	DIST -	REVISIONS		
P	LTR	DESCRIPTION	DATE	DWN
		SEE SHEET 1		APVD

NOTES:

- 1. DIMENSION:
TRAY: 345mm(L)x225mm(W)x19mm(H)
SHIPPING BOX: 360mm(L)x240mm(W)x207mm(H)
- 2. QUANTITY:
100 PCS/TRAY
10 TRAYS/SHIPPING BOX(=1000 PCS)
- 3. WEIGHT:
GROSS WEIGHT: 9.9KGS/SHIPPING BOX FOR PN1734717-1
7.98KGS/SHIPPING BOX FOR PN1734717-2

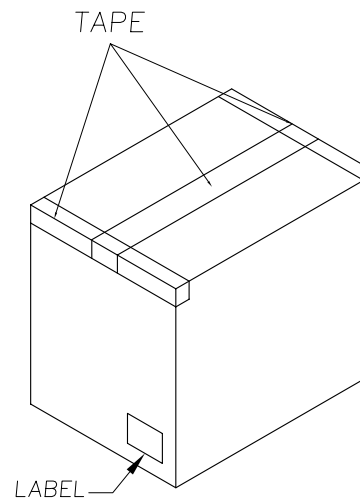
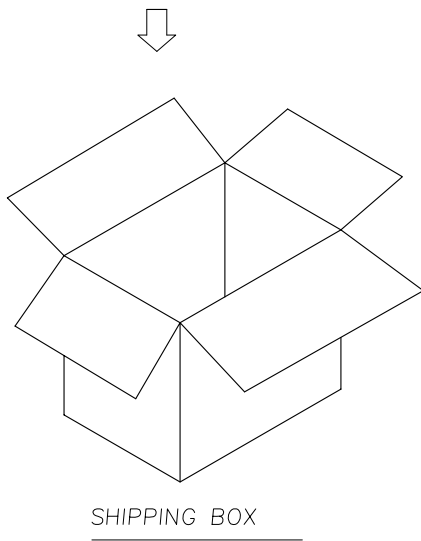
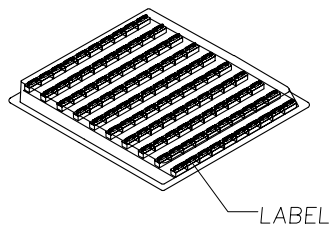
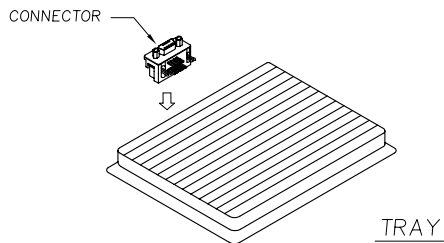
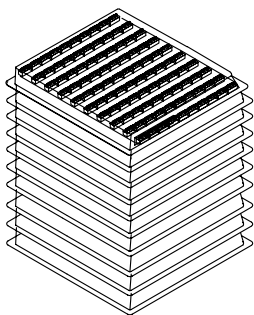
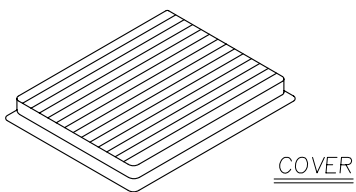

1734717-2
1734717-1
PART NUMBER

THIS DRAWING IS A CONTROLLED DOCUMENT.		DWN	TE TE Connectivity		
DIMENSIONS: MM		CHK			
TOLERANCES UNLESS OTHERWISE SPECIFIED:		APVD	D-SUB 9POS. RCPT, R/A DIP TYPE		
0 PLC ± -		PRODUCT SPEC	QUALIFICATION TEST REPORT		
1 PLC ± -		QUALIFICATION TEST REPORT	SIZE	CAGE CODE	DRAWING NO
2 PLC ± -		QUALIFICATION TEST REPORT	A3	00779	C=1734717
3 PLC ± -		WEIGHT	CUSTOMER DRAWING		
4 PLC ± -		WEIGHT	SCALE	SHEET	REV
ANGLES ± -		WEIGHT	-	2 of 3	A1
MATERIAL SEE NOTE	FINISH SEE NOTE				

THIS DRAWING IS UNPUBLISHED. RELEASED FOR PUBLICATION
© COPYRIGHT BY TYCO ELECTRONICS CORPORATION. ALL RIGHTS RESERVED.

LOC	DIST	REVISIONS					
DW	-	P	LTR	DESCRIPTION	DATE	DWN	APVD
				SEE SHEET 1			

- NOTE:
- MATERIAL:
TRAY: PVC
SHIPPING CARTON: CORRUGATED FIBER
BAG: LOW DENSITY POLYETHYLENE
 - DIMENSION:
TRAY: 345mm(L)x225mm(W)x19mm(H)
SHIPPING CARTON: 360mm(L)x240mm(W)x207mm(H)
 - QUANTITY:
100 PCS/TRAY
10 TRAYS/SHIPPING CARTON(=1000 PCS)
SCREW QTY: 2000PCS/SHIPPING CARTON
 - WEIGHT:
GROSS WEIGHT: 9.9KGS/SHIPPING CARTON FOR PN1734717-3

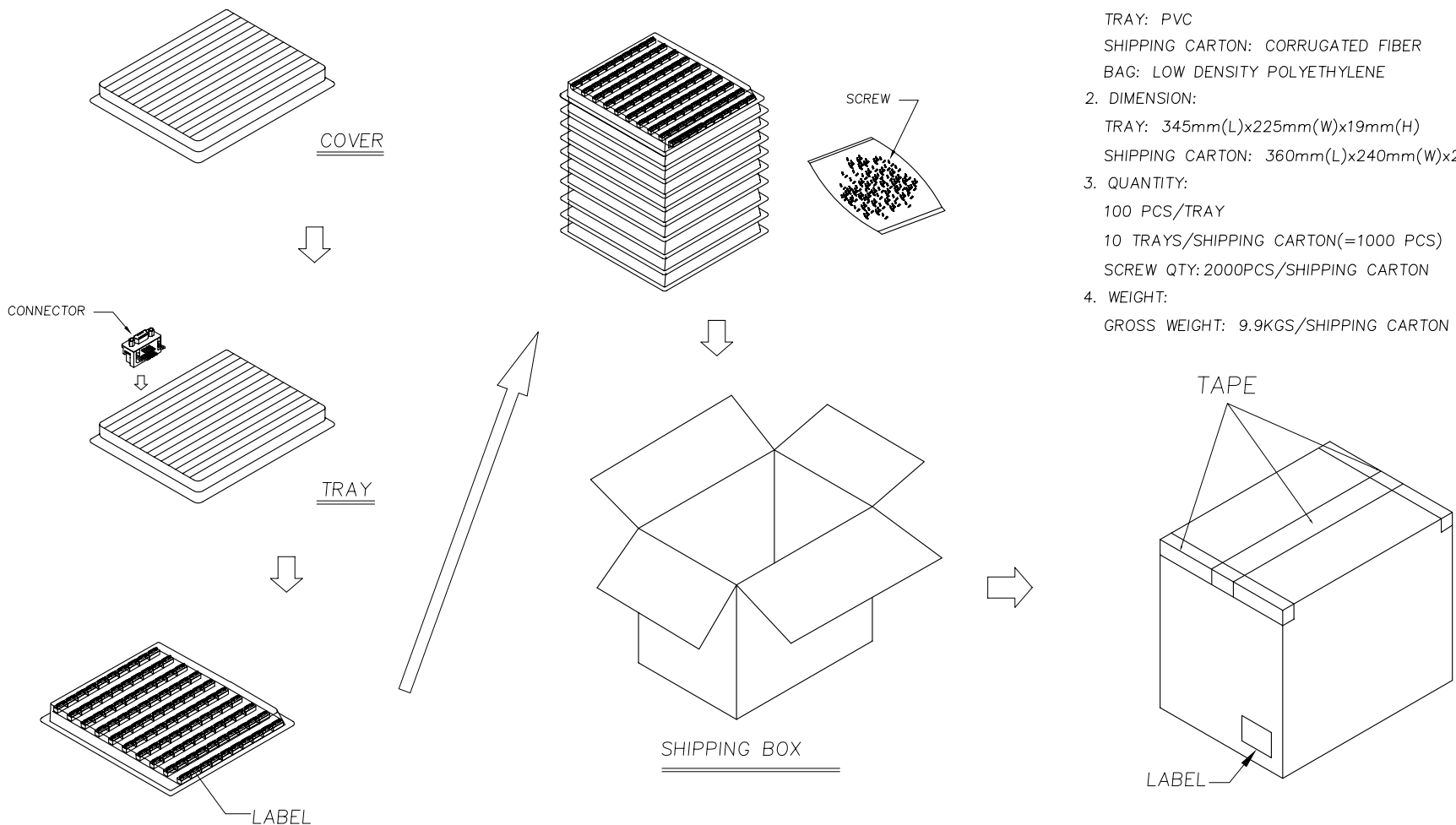

OBSOLETE

1734717-3
PART NUMBER

THIS DRAWING IS A CONTROLLED DOCUMENT.		DWN	TE Connectivity	
DIMENSIONS: MM		CHK	NAME	
TOLERANCES UNLESS OTHERWISE SPECIFIED:		APVD	D-SUB 9POS. RCPT, R/A DIP TYPE	
0 PLC ± -	1 PLC ± -	PRODUCT SPEC	SIZE	CAGE CODE
2 PLC ± -	3 PLC ± -	QUALIFICATION TEST REPORT	A3	00779
4 PLC ± -	ANGLES ± -	WEIGHT	DRAWING NO	
MATERIAL SEE NOTE	FINISH SEE NOTE	CUSTOMER DRAWING	C=1734717	
		SCALE	SHEET	REV
		-	3 of 3	A1